

.192 [4.88] ROD DIAM



1.08 [27.4] BELT PITCH

NOTES:

1. WIDTHS VARY BY ORDER

DO NOT SCALE DRAWING

APPROVALS

DATE

DRAWN witrinc

5/2/2013

UNLESS OTHERWISE SPECIFIED DIMENSIONS ARE IN INCHES.

TOLERANCES:
 .X = ± .03 FRACTION ± 1/16
 .XX = ± .015 ANGLES ± 1/2°
 .XXX = ± .005
 .XXXX = ± .0005 SURF FINISH 63 ✓



Ashworth Bros., Inc.

450 ARMOUR DALE, WINCHESTER, VA 22601

TITLE

ILLUSTRATION OP100 B60-12-17

SIZE

B

DWG. NO.

REV.

CAD/FILE NAME
OP Assembly.idw

SCALE

1 : 1

CALC.WT

N/A

SHEET

1 OF 2

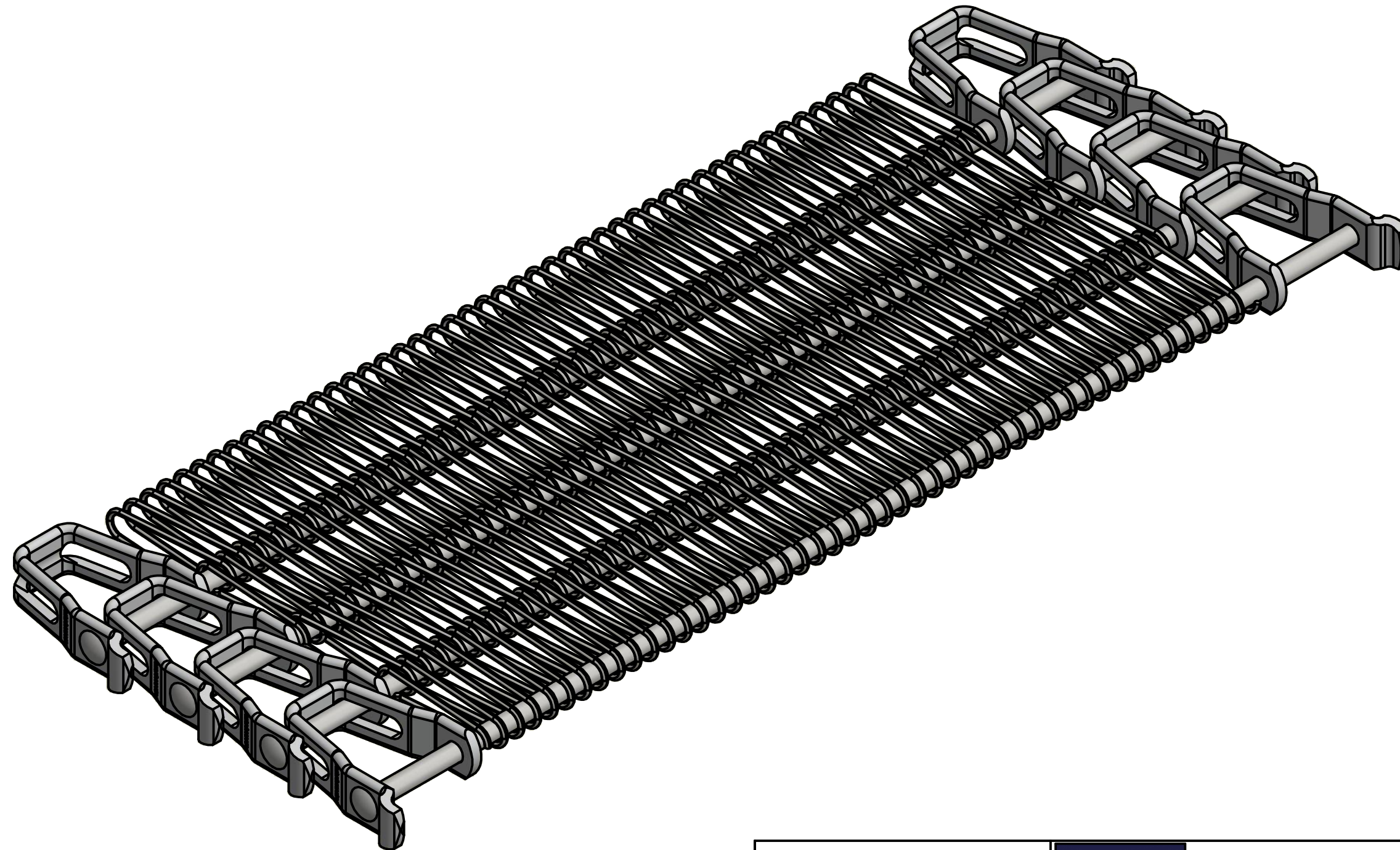

DO NOT SCALE DRAWING		 Ashworth Bros., Inc. 450 ARMOUR DALE, WINCHESTER, VA 22601
APPROVALS	DATE	
DRAWN	witrinc	5/2/2013
UNLESS OTHERWISE SPECIFIED DIMENSIONS ARE IN INCHES. TOLERANCES: .X = ± .03 FRACTION ± 1/16 .XX = ± .015 ANGLES ± 1/2° .XXX = ± .005 .XXXX = ± .0005 SURF FINISH 63 ✓		TITLE
		ILLUSTRATION OP100 B60-12-17
SIZE	B	DWG. NO.
SCALE	1 : 1	REV.
CAD/FILE NAME	OP Assembly.idw	CALC.WT
		N/A
		SHEET
		2 OF 2