

NOTES:

THIS DRAWING CONTAINS CONFIDENTIAL INFORMATION AND TRADE SECRETS OF ASHWORTH BROS., INC. IT MAY NOT BE REPRODUCED IN WHOLE OR IN PART OR USED FOR THE BENEFIT OF ANYONE OTHER THAN ASHWORTH BROS., INC. NO RIGHT IS GRANTED TO DISCLOSE OR USE ANY INFORMATION SHOWN ON THIS DRAWING.

UNLESS OTHERWISE SPECIFIED DIMENSIONS ARE IN INCHES. TOLERANCES: .X = ± .03 FRACTION ± 1/16 .XX = ± .015 ANGLES ± 1/2° .XXX = ± .005 .XXXX = ± .0005 SURF FINISH ✓ 63	CONTRACT / PROJECT NO.		 Ashworth Bros., Inc. 450 ARMOUR DALE, WINCHESTER, VA 22601		
	APPROVALS	DATE			
	DO NOT SCALE DRAWING	DRAWN witrinc	3/5/2020	TITLE ILLUSTRATION OG360-150 U54-8-16	
	THIRD ANGLE PROJECTION 	DESIGN CST	3/28/2017		
MATERIAL	REF ASSEMBLY	SIZE	CAGE CODE	QUOTE NO.	REV.
TREATMENT NONE	REF PART	B	96664		
FINISH NONE	ASHWORTH PART NUMBER	SCALE	CALC.WT	SHEET	
		1 : 1	N/A	1 OF 2	

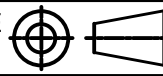
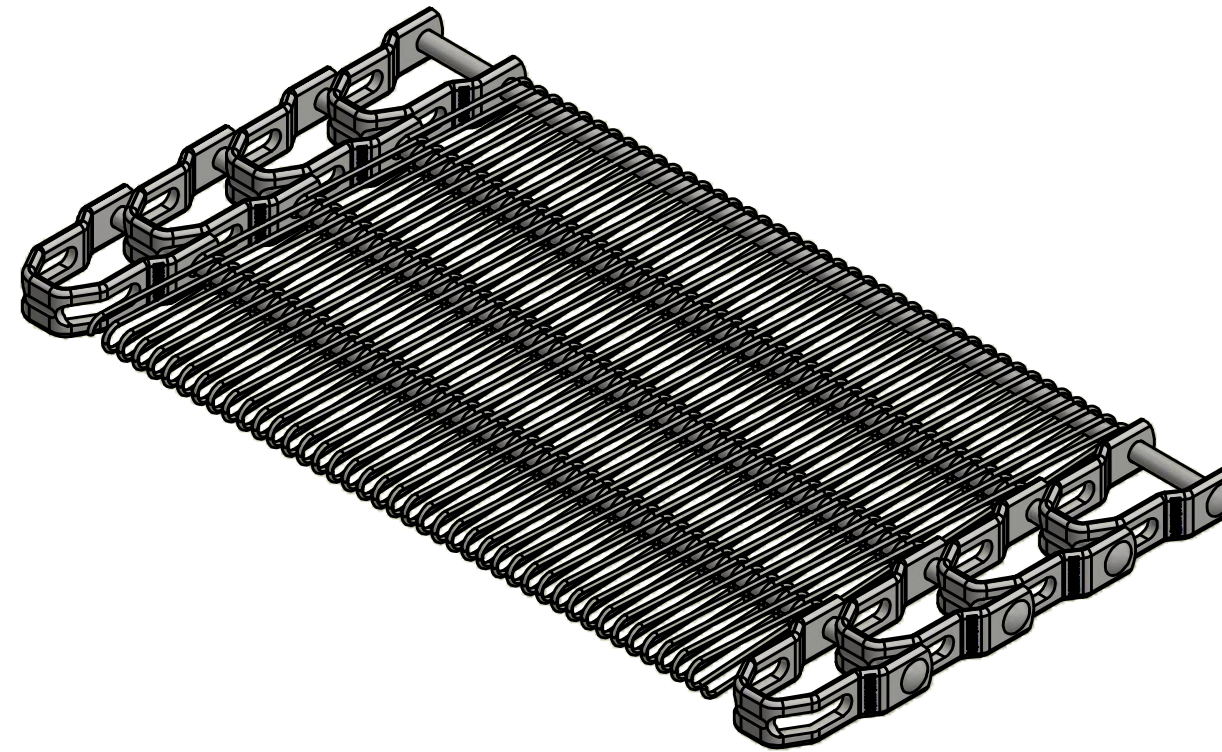

ISO VIEW
SCALE 1 / 2

THIS DRAWING CONTAINS CONFIDENTIAL INFORMATION AND TRADE SECRETS OF ASHWORTH BROS., INC. IT MAY NOT BE REPRODUCED IN WHOLE OR IN PART OR USED FOR THE BENEFIT OF ANYONE OTHER THAN ASHWORTH BROS., INC. NO RIGHT IS GRANTED TO DISCLOSE OR USE ANY INFORMATION SHOWN ON THIS DRAWING.

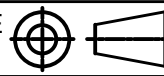
UNLESS OTHERWISE SPECIFIED DIMENSIONS ARE IN INCHES. TOLERANCES: .X = ± .03 FRACTION ± 1/16 .XX = ± .015 ANGLES ± 1/2° .XXX = ± .005 .XXXX = ± .0005 SURF FINISH ✓ 63	CONTRACT / PROJECT NO.		 Ashworth Bros., Inc. 450 ARMOUR DALE, WINCHESTER, VA 22601			
	APPROVALS	DATE				
DO NOT SCALE DRAWING	DRAWN witrinc	3/5/2020	TITLE ILLUSTRATION OG360-150 U54-8-16			
THIRD ANGLE PROJECTION 	DESIGN CST	3/28/2017				
MATERIAL	CHECKED		SIZE	CAGE CODE	QUOTE NO.	REV.
TREATMENT NONE	REF ASSEMBLY		B	96664		
FINISH NONE	REF PART		SCALE	1 : 1	CALC.WT N/A	SHEET 2 OF 2
	ASHWORTH PART NUMBER					